

G-CAT

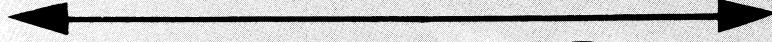

5 • METER

G-CAT INTERNATIONAL INC.

269 16th Street North, St. Petersburg, Florida, 33705 (813) 621-6881

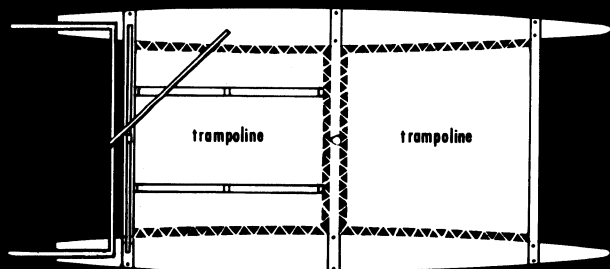
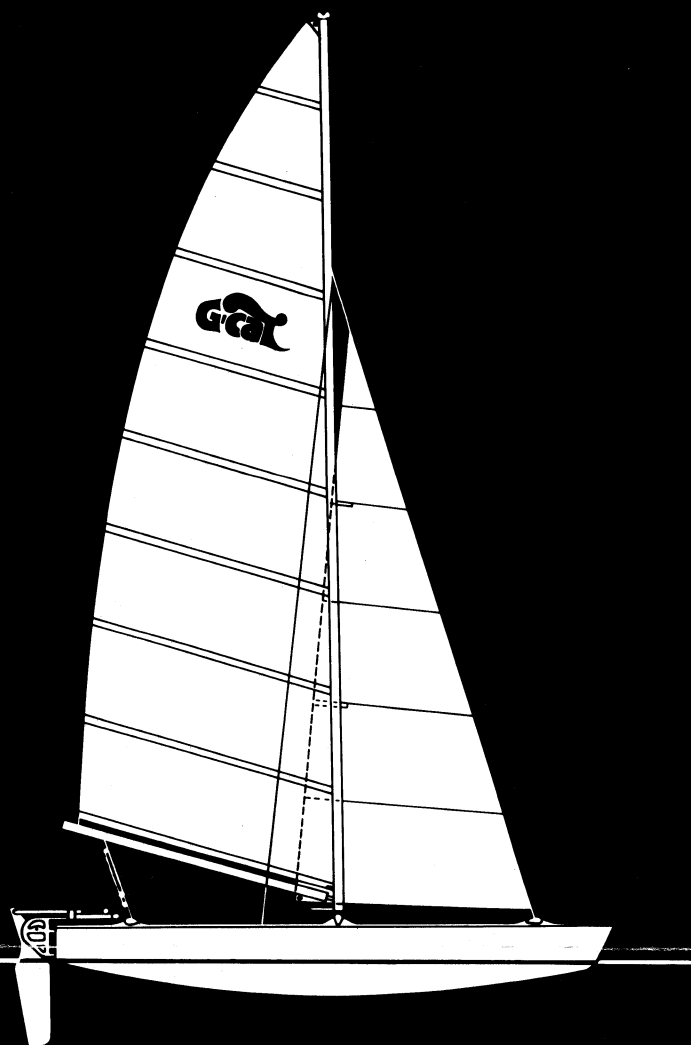

SPECIFICATIONS

LOA	16'8"	Sail Area	
LWL	15'6"	Main & Spars	150 sq. ft.
Beam	8'	Jib	60 sq. ft.
Mast	27'	Total Sail Area	210 sq. ft.
Weight	340 lbs.	Racing Crew	2

FEATURES

- Hand Laid-Up Fiberglass Hulls
- 5.3 oz. Sails
- Stainless Steel Rigging
- Three Beams Connect the Hulls
- Mast Rotation Control
- Roller Bearing Traveler
- Fully Mechanized Kick-up Rudders
- 5:1 Mainsheet Blocks
- Main Out and Down Haul
- Adjustable Hiking Stick
- Adjustable Trapeze
- Weatherproof Mesh Trampoline

The **G-CAT 5-METER** is a revolutionary, all-purpose catamaran originated by Hans Geissler, a catamaran pioneer in the South Eastern United States. Five years of durability testing, aerodynamic computer analysis, and the application of spot placing boats throughout the country, has resulted in a comfortable solution to every sailor's needs.

The **G-CAT 5-METER** combines a no-dagger-board, symmetrical design with best windward performance. That is unusual! Until the G-CAT appeared on the scene, it was believed that catamarans either had to have daggerboards (problematic in shallow water and on the beach) or be of asymmetrical hull design (more drag).

Windward performance of the G-CAT equals, or surpasses, that of any asymmetrical catamaran on the market. The flow of water along the well-faired symmetrical hulls is less turbulent. The deep-V and sharp entry over the full length of the G-CAT hulls eliminates pounding and stalling when driving into the waves. This assures a soft, drier — more comfortable ride through choppy waters.

Well designed, well built and fast — the catamaran with a forward trampoline — space for comfortable sailing. The third beam not only strengthens and stabilizes construction but supports the forward trampoline. Your G-CAT has over 80 sq. ft. of space for you and your family to enjoy. That's twice the area you'll find on any cat. Rig the tent, and you're ready to camp.

The family catamaran that flies is double trapezed with a forward trampoline. The perfect family beach catamaran that wins races. The G-CAT can be your keep-fit exercise machine, or a laze-about sun deck. If it's social excitement or racing you're after, join one of the many G-Cat fleets now forming all over the country!

SOME RACE RESULTS:

The North American Multihull Sailing Association rates the G-CAT 5-METER the fastest non-board catamaran under 18 ft. with a Portsmouth Handicap Number of .760.

- 1979 PMA World Speed Trials** . . . 1st place
(most efficient cat)
- NAMSA Championships** . . . 1st & 3rd place,
Open Div.
2nd overall
- 1980 24th Miami-Key Largo** . . . 1st place,
Open Div.
- Holland's "Round Texel" Race** . . . 1st place,
Open Div.
- NAMSA Championships** . . . 1st & 2nd place,
Open Div.
2nd & 5th place
overall
- PMA World's Speed Trials** . . . Fastest Cat
Under 36 ft.
- 1981 Yachting "One of a Kind Speed Trials"** . . . Winner
- 1982 Holland's "Round Texel" Race** . . . 1st place,
Open Div.

5 • METER ASSEMBLY MANUAL

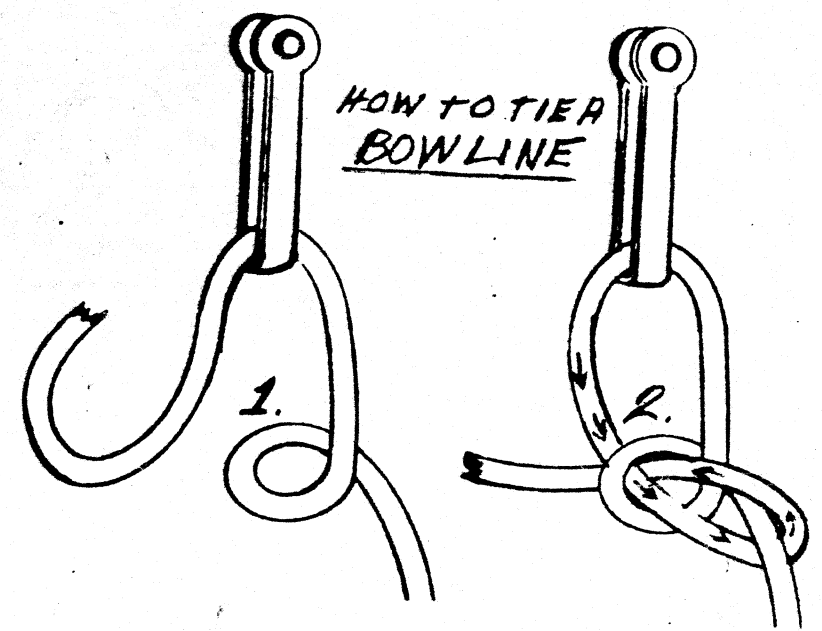

SEE DETAIL I FOR MAIN OUTHAUL & BLOCK SYSTEM

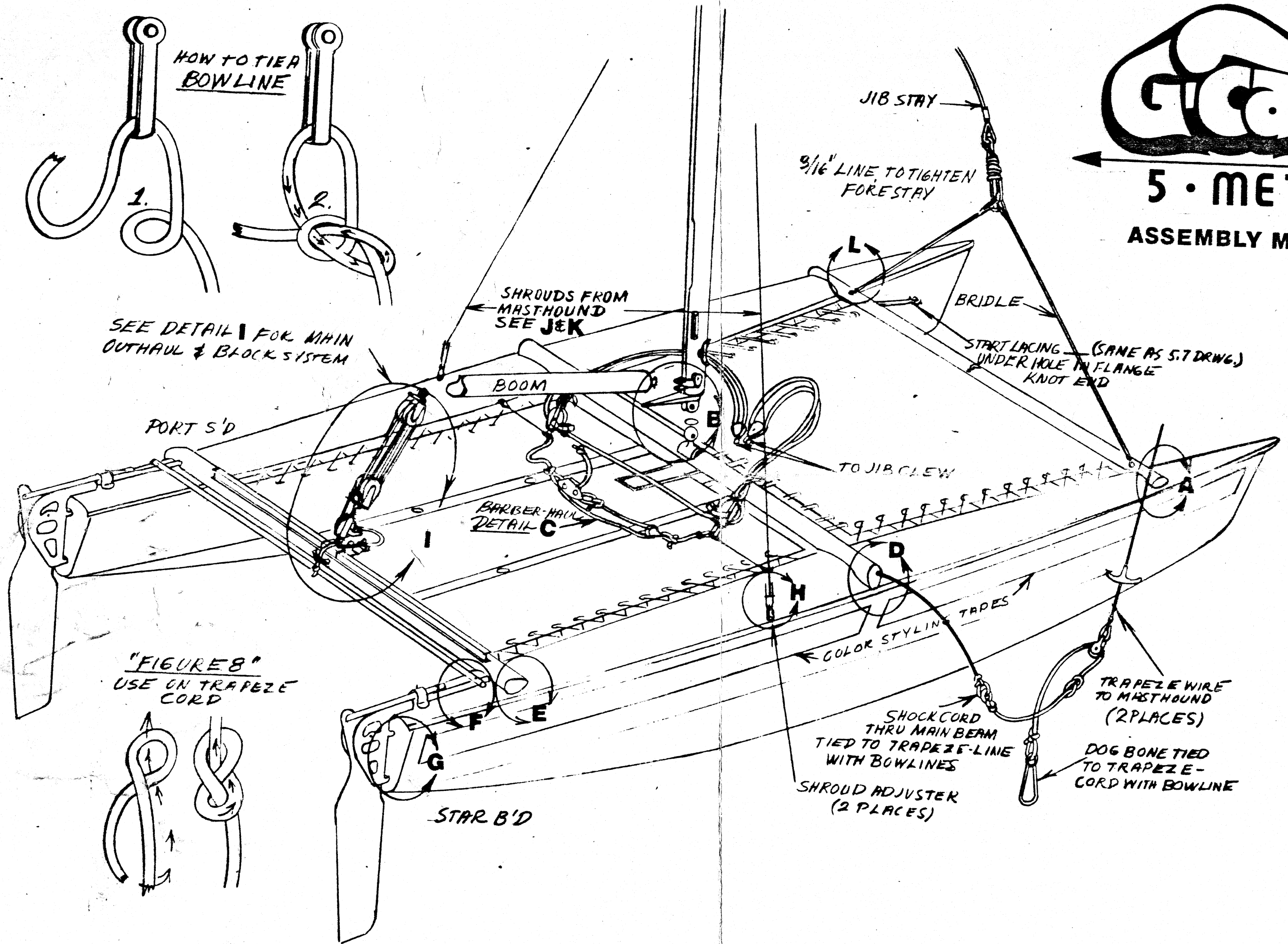

"FIGURE 8" USE ON TRAPEZE CORD

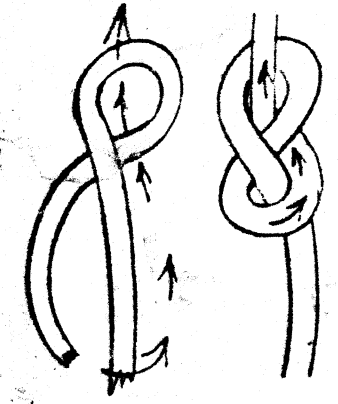

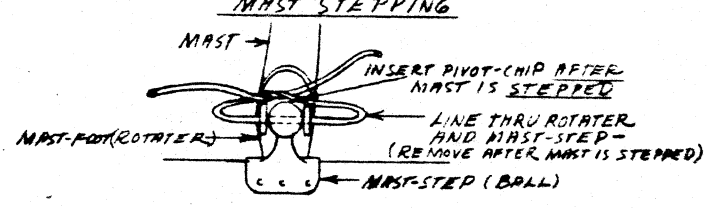
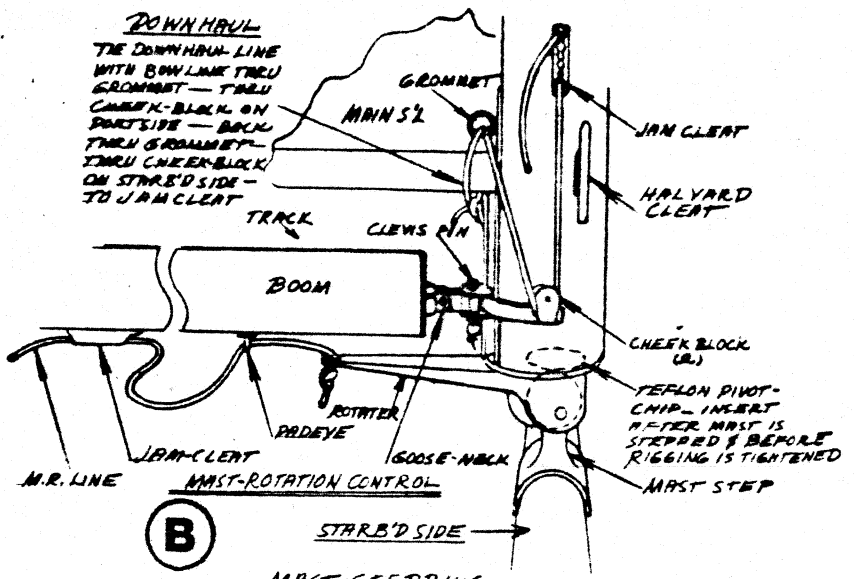
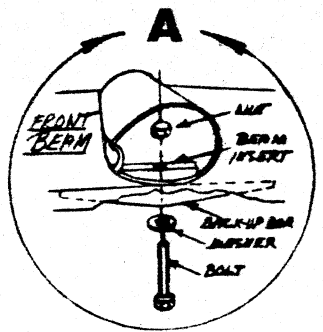

MAKE SURE SHROUDS ARE ATT. TO RIVETERS & ALL RIGGING IS UNOBSTRUCTED ATT. MAST FOOT TO BALL-BASE WITH SHORT LINE. LIFT MAST TO UP-RIGHT POSITION. ATT. FORESTAY BUT INSERT TEFALON PIVOT-CHIP BEFORE TENSION IS APPLIED REMOVE LINE FROM STEP & ROTATER.

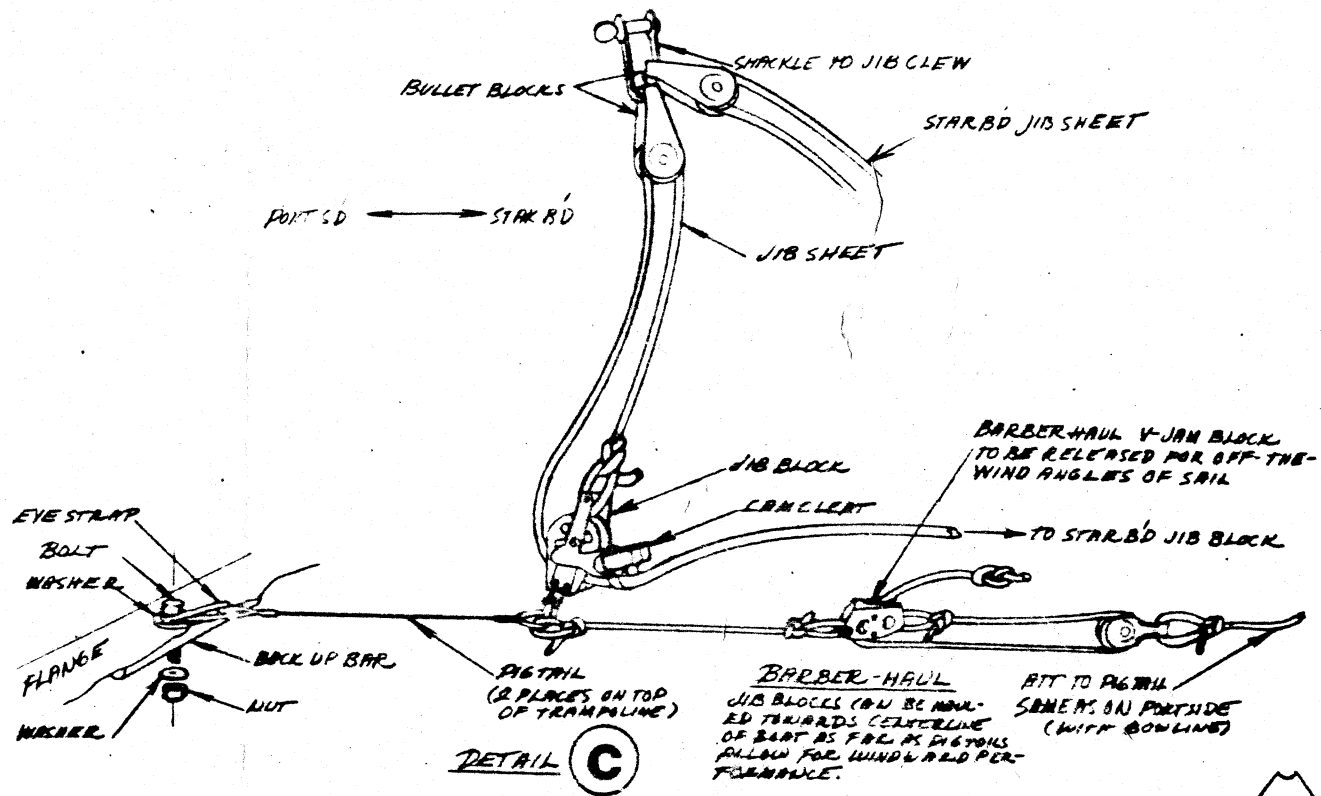
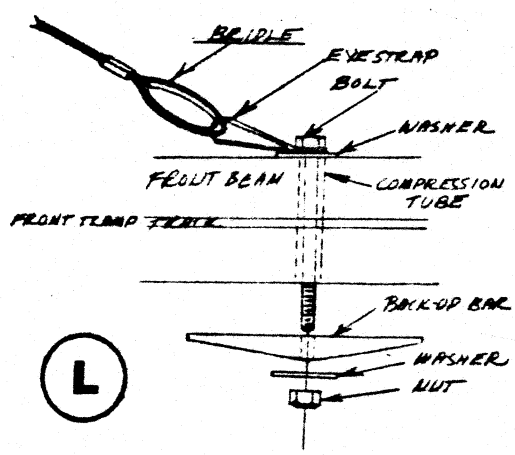
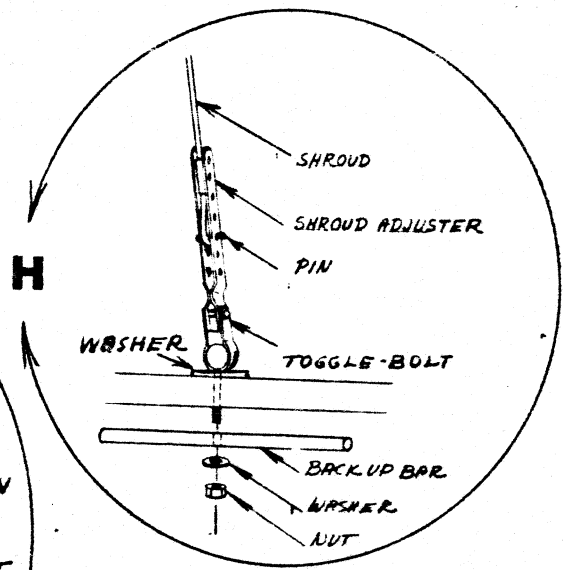
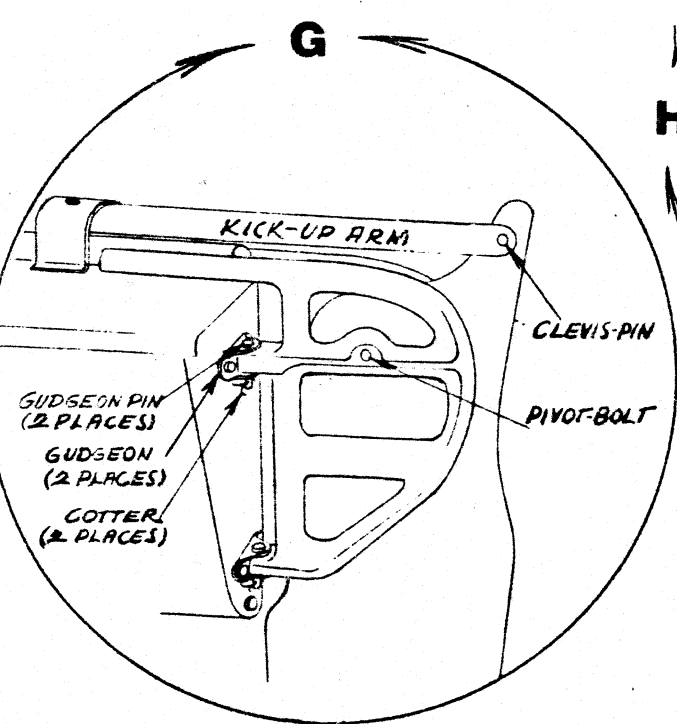
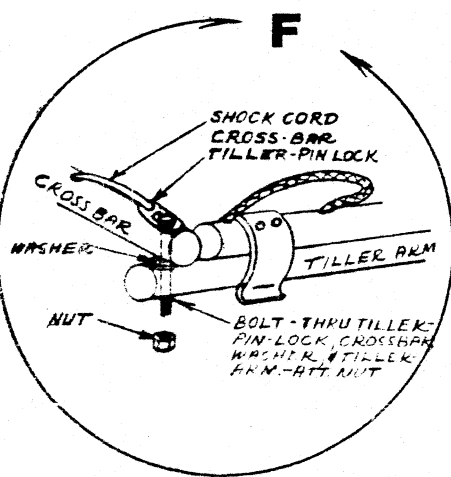

BARBER-HAUL ATT TO PISTON JIB BLOCKS CAN BE MANEUVERED TOWARDS CENTERLINE OF BOAT AS FAR AS PISTONS ALLOW FOR WINDWARD PERFORMANCE. ATT TO PISTON SAME AS ON PORTSIDE (WITH BOWLINE)

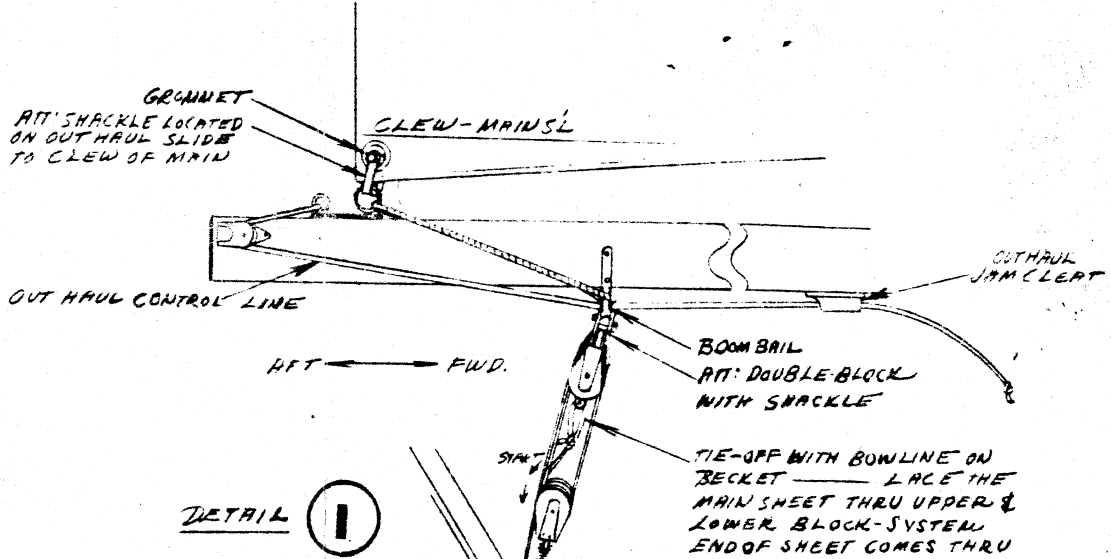
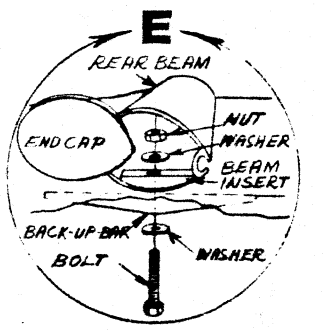
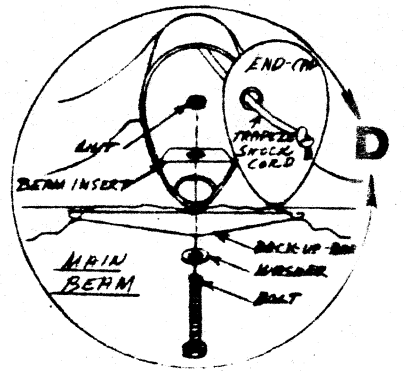

SEE DETAIL I-A FOR LOWER-BLOCK ATTACHMENT TO TRAVELER CAR

