

STANDARD EQUIPMENT

5 Year Limited Warranty
Molded White Hulls with Non-Skid
Decks
Harken Hardware
Kick-up Rudder System
Matching Main and Jib Colors

Hinged Mast Step System
Beam Mounted Jib Blocks
Clear Anodized Aluminum Rig
Coated Shrouds
Mesh Trampoline
Fiberglass Battens

Tiller Extension
Hull Graphics
Reinforced Keel
Window in Jib
Manual Furling Jib

The Prindle Escape: Carefree And Simple Sailing For The Recreational Sailor

Utilizing all the fun features of a spirited catamaran, coupled with a simple and sturdy design, the Escape offers long lasting performance for the recreational sailor. The Escape is designed with a number of specific features to provide both low maintenance and longevity. And best of all, the Escape is extremely easy and safe to sail.

An innovative bridle mount system results in a larger jib that propels the Escape at exciting speeds and allows for easier tacking.

The Escape also offers an optional rack system called "CatRax" which adds a new dimension to sailing comfort.

Structurally sound hull and deck construction and a Kevlar reinforced keel assure years of off the beach sailing. The asymmetrical hulls also eliminate the



need for daggerboards, which makes the Escape an ideal beach boat. Powering the Escape is a modest sized sailplan and self-furling jib. The boomless rig and lack of mast spreaders also help to eliminate weight and add sailing comfort.

Ease of handling is the trademark of the Escape. Whether single or doublehandling or out with a group of friends, the Escape will offer years of carefree, comfortable sailing.

Specifications

Length 18' (5.49m)
Width 7' 11" (2.44m)
Draft (boards up) . . . 9" (22.86cm)
 (boards down) . . 22" (55.88cm)
Sail Area 210 sq. ft. (19.5m²)
Weight 335 lbs. (152 kg)
Mast Length 26' (7.92m)

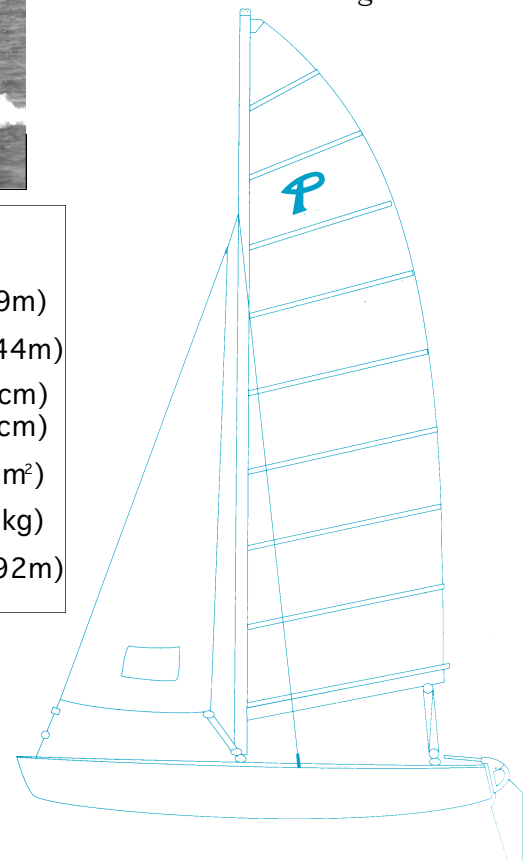

Authorized Dealer: